

Across the board

PIAVAL

Piaval

Across the board

Piaval

- 3 Piaval, tradition and craftsmanship
- 4 Technology and quality Made in Italy
- 17 Sustainability and care

Cameo

- 21 Sofa, armchair, chair, stool, seat modules

Earl

- 43 Armchair, chair, stool

Liv

- 57 Armchair

Elsa squared version

- 71 Armchair, chair, stool

Pia

- 85 Armchair, chair

Across the families

- 101 Products overview

Piaval

Tradition and craftsmanship

The artisan approach to the manufacturing of each Piaval product, the deep knowledge of the material, the tailoring of the details are the result of a tradition that boasts a century of specialization in the production of wooden seats. The knowledge of craftsmanship grows, day after day, with care and passion. This has been the Piaval philosophy for four generations.

L'approccio artigianale nella realizzazione di ogni prodotto Piaval, la profonda conoscenza della materia, la cura sartoriale dei dettagli sono il risultato di una tradizione che vanta un secolo di specializzazione nella lavorazione delle sedute in legno. Il sapere artigiano nasce per addizione, giorno dopo giorno, con impegno e passione. Piaval lo testimonia da quattro generazioni.

www.piaval.it

Technology and quality

Made in Italy

Product innovation, technologically advanced industrial processes and ergonomic research combine with craftsmanship. Piaval design is constantly measured with the customization needs arising from the Contract sector, combining design and Made in Italy quality with functional and versatile solutions which are the result of the collaboration with prominent international designers.

Innovazione di prodotto, processi industriali tecnologicamente avanzati e ricerca ergonomica si sommano alla cura artigianale. La progettazione Piaval si misura costantemente con le esigenze di customizzazione dei professionisti del Contract, coniugando design e qualità Made in Italy a soluzioni funzionali e versatili, frutto della collaborazione con affermati designer internazionali.





Contract design

A blend of versatility and aesthetics, designed to meet the needs of contemporary hospitality projects.

Un connubio di versatilità ed estetica, pensato per le esigenze del contract contemporaneo.



Pleasant tactility

**Clean and simple profile,
entrusting to precious materials
the expressiveness of the project.**

Linee asciutte ed essenziali affidano
alla preziosità dei materiali
l'espressività del progetto.



Quality furniture is timeless

100 years of wood craftsmanship.

100% Made in Italy.

100 anni di esperienza nella
lavorazione del legno.

100% Made in Italy.



Tradition and Technology

Eaesthetic research, advanced industrial production and artisan knowledge.

Ricerca estetica, sistemi di produzione avanzati e sapere artigianale.



Tailored solutions

Formal balance of different colors and materials for tailored-made solutions.

Un equilibrio di materiali e colori, flessibili nel livello di personalizzazione.



Sustainability and Certifications

The concrete commitment to the environment has always identified Piaval's chain, characterised by the low environmental impact processes, the production of clean energy, the recycling of waste as biomass and the use of compounds not harmful to health. On request, the products are made of FSC® wood. The same consideration is given to the quality, through certifications attesting the control of processes, the safety and durability to the products and their ergonomics.

L'impegno concreto per l'ambiente identifica da sempre i processi produttivi Piaval, caratterizzati da lavorazioni a basso impatto ambientale, dalla produzione di energia pulita, dal riciclo degli scarti come biomassa e dall'utilizzo di composti non dannosi per la salute. A richiesta, i prodotti sono realizzati con legname FSC®. Analoga attenzione è data alla qualità, attraverso certificazioni che attestano il controllo dei processi, la sicurezza e la durata dei prodotti, la loro ergonomia.

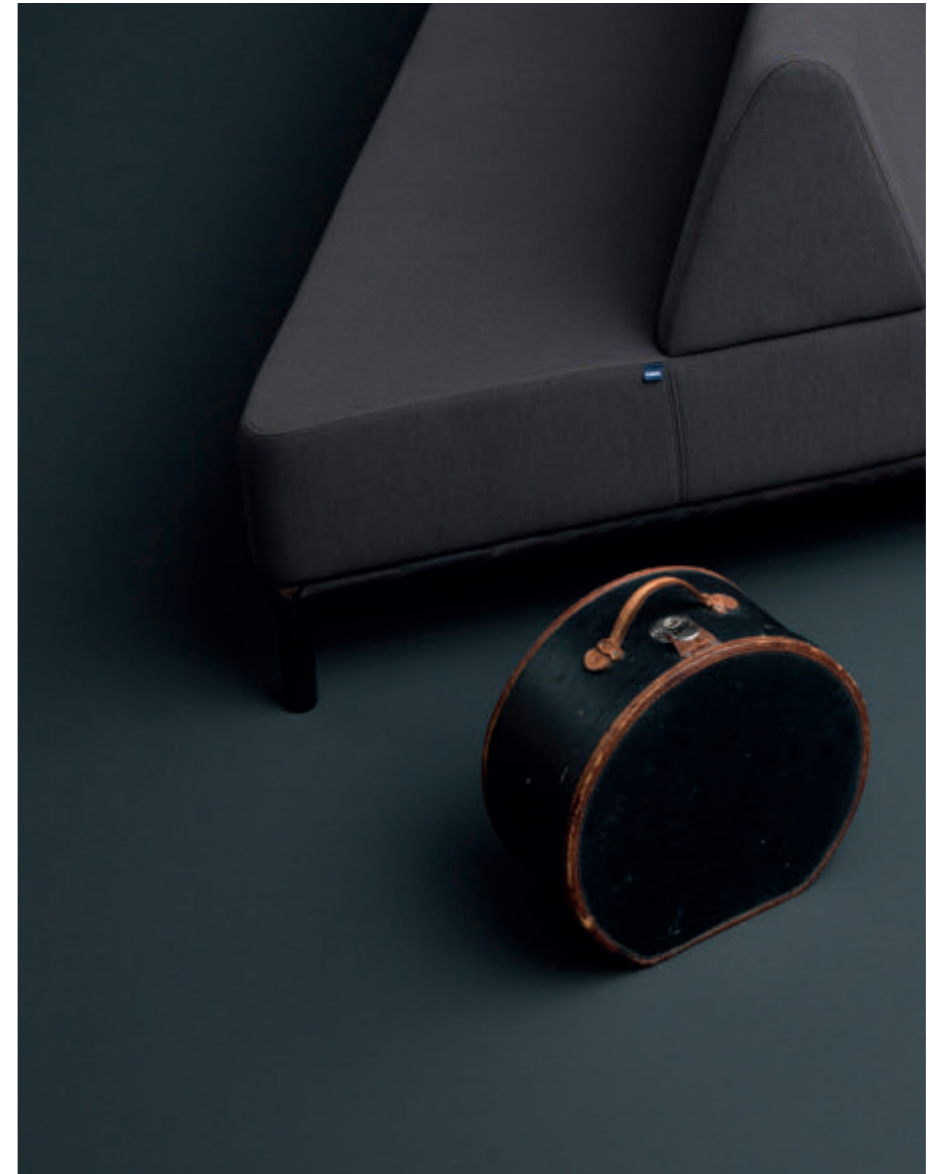

Cameo



**Cameo**

design Edi e Paolo Ciani

A sophisticated design, matched by international demand for elegant and contemporary hospitality projects.

Un design sofisticato interpreta la richiesta di interni contract contemporanei e cosmopoliti.



Woods and volumes

**Shaped ash wood to frame
the structure.**

Frassino modellato a
incorniciare il profilo.





Contemporary verve

**The perfect combination
of proportions,
modularity and comfort.**

La perfetta combinazione
tra proporzioni,
modularità e comfort.





Tactile and precious fabrics

Delicacy and balance in the choice of materials.

Ricercatezza ed equilibrio nella scelta dei materiali.





Modular design

A sitting system for lounges and waiting areas, constantly evolving.

Un sistema di sedute in continuo divenire, per lounge e aree d'attesa.



Know-how in processing

An in-depth knowledge of wood brings stability and robustness.

La profonda conoscenza del legno si tramuta in stabilità e robustezza.





Elective affinities

**Individual modules,
paired with oversize
coffee tables.**

Sedute modulari, abbinare
a tavolini oversize.





Functional solutions

**Large, comfortable,
highly flexible.**

Ampio, confortevole,
flessibile ad ogni esigenza.





A new minimal

**A sculptural expression
of comfort.**

Un comfort dai tratti
scultorei.

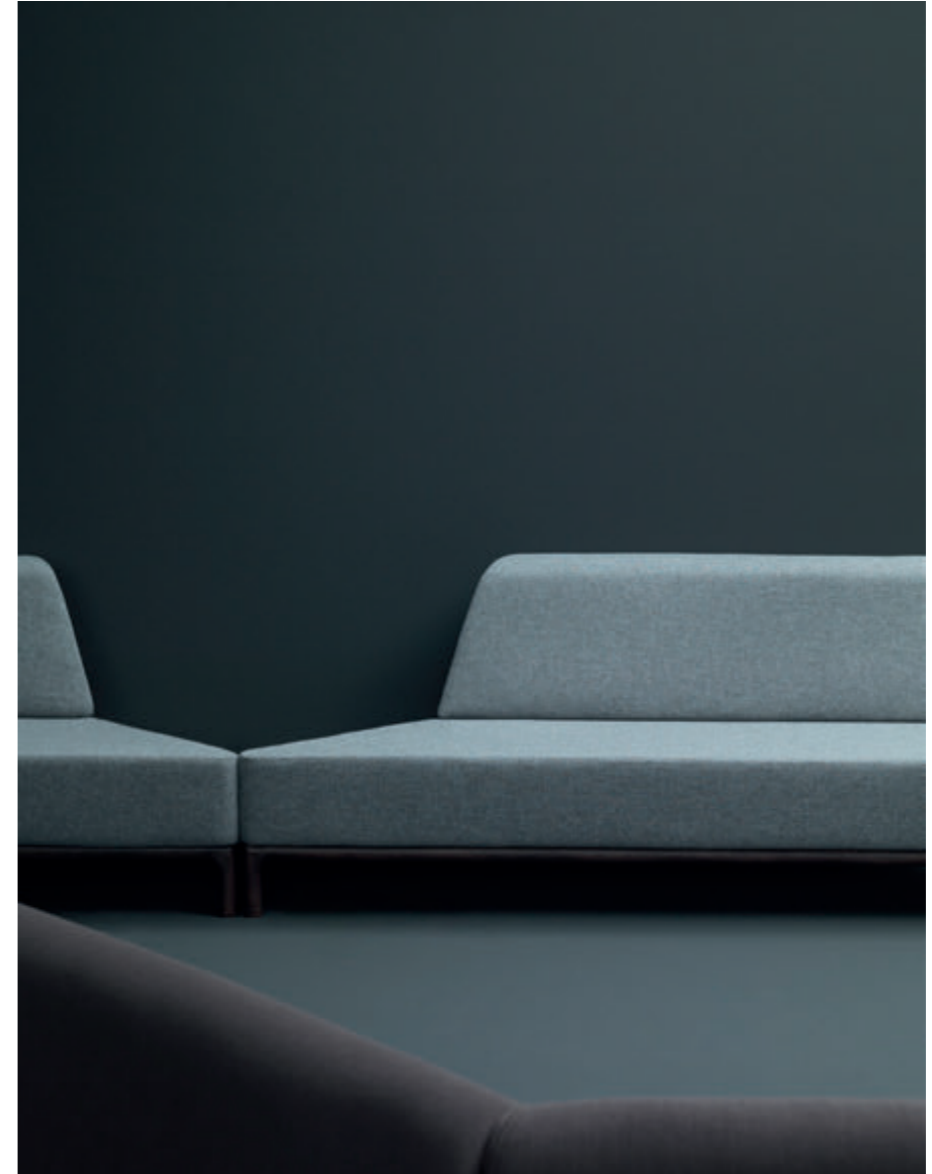

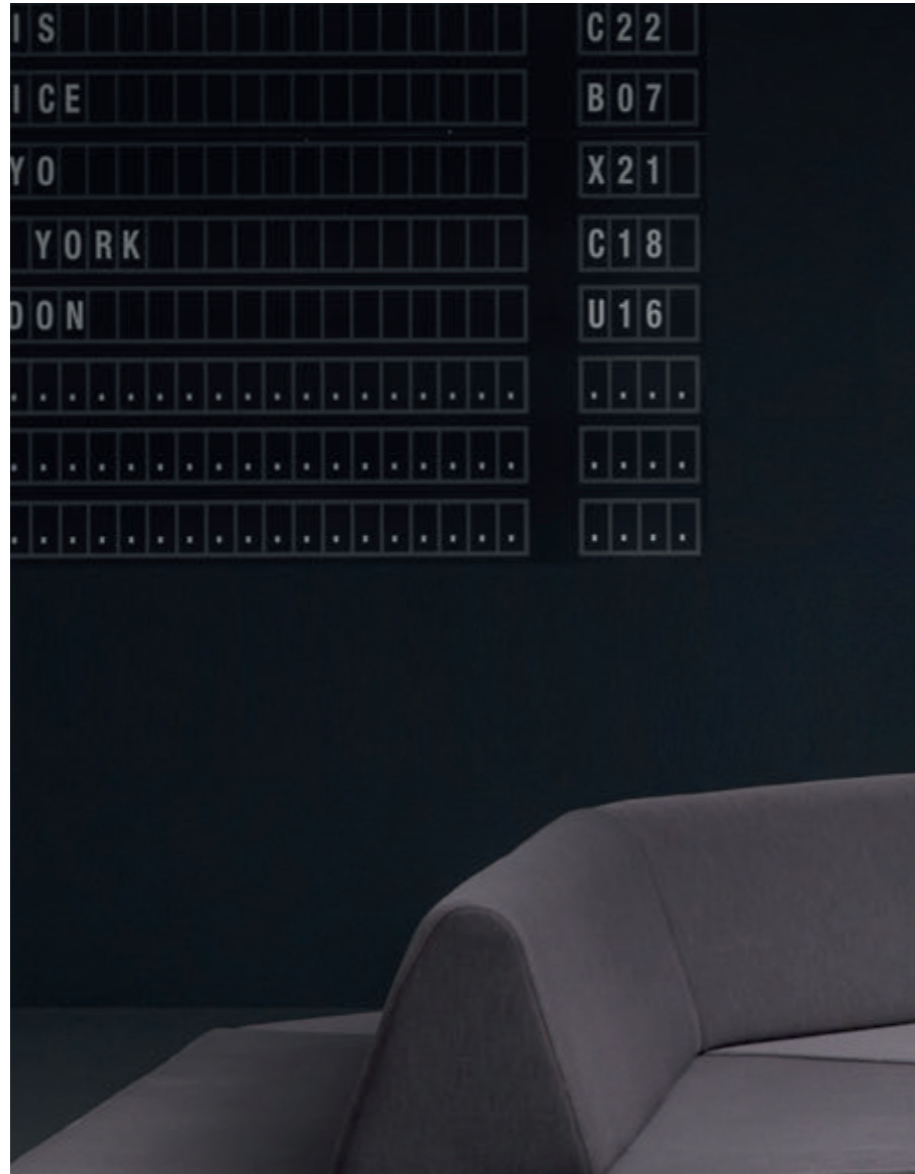

A strong graphic presence

**A trapezoid shape marks out
two symmetrical seats.**

Una geometria trapezoidale
disegna due sedute speculari.

Earl





Earl
design Daniel Rous / Fabrica

**Elegance flows from a
beautiful simplicity.**
L'eleganza è meravigliosa
semplicità.



Design with a story

**Innovation and complex
woodworking skills,
concealed in simple design.**

Un segno minimale cela
innovazione e competenza
nella lavorazione del legno.





Dual Identity

The variation on the theme comes with a padded seat.

Variazione sul tema grazie al sedile imbottito.





Wood passion

**Massive bent beech worked
in thin sections.**

Massello di faggio curvato,
lavorato a sezioni sottili.





Stability and comfort

**Seat in full solid wood,
carved to ensure ergonomics
and good posture.**

Sedile in massello pieno,
scavato per ottenere
un'impronta ergonomica.





Distinctive character

The backrest is shaped into a harmonious curve.

Lo schienale disegna una curva armoniosa.

Liv





Liv
design David Ericsson

A sartorial classic that involves the most profound sensoriality, expressed in exclusive details.
Un classico sartoriale, sensazioni tattili espresse in dettagli esclusivi.



More than an armrest

**Maximum solidity
for heavy use.**

Massima robustezza per il
contract.





Stitching details

Attention to details and new materials.

Cura sartoriale e nuove proposte materiche.





Not only appearance counts

**Sitting comfortable at
restaurants, hotels and lounges.**

Stare comodamente seduti al
ristorante, in albergo, nella lounge.





An enveloping, private space

**Soft curves that enhance
an intimate dimension.**

Morbide curve regalano una
dimensione intima.

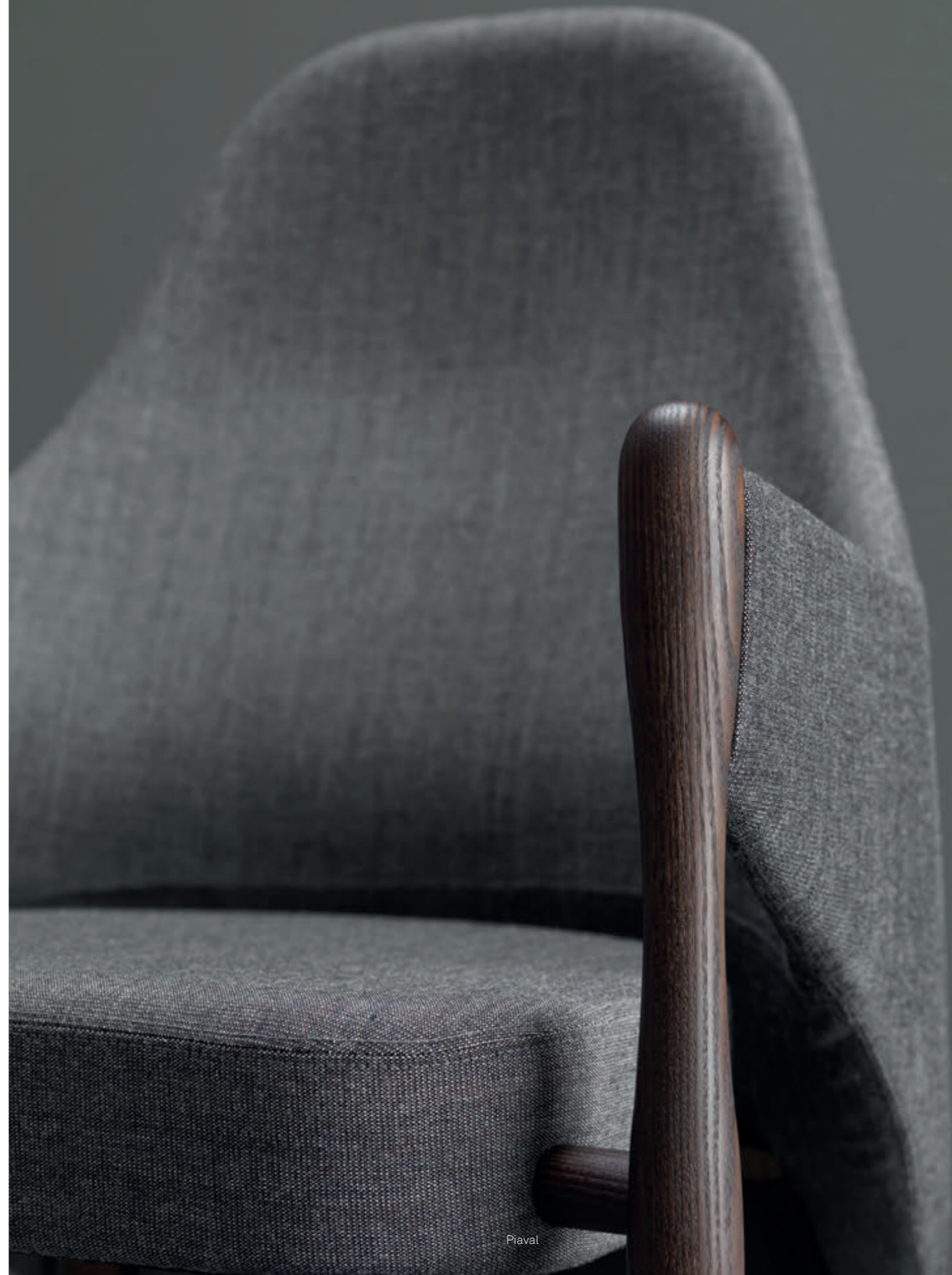



Elsa
Squared version





Elsa
design David Ericsson

**Scandinavian lightness, sturdy
durability and usage versatility.**

Leggerezza scandinava, solida
durevolezza e versatilità d'uso.



Squared version

Straight lines emphasizing structure solidity.

Linee rigorose esaltano la solidità della struttura.





Wood shaped in dynamic effects

Armrests opening outwards and shaped seat guarantee unexpected levels of comfort.

I braccioli che si aprono e la lieve sagomatura del sedile garantiscono un comfort inaspettato.





Pragmatism and elegance

**An upholstered version,
inviting to comfortably seat.**

Versione imbottita, per il
massimo comfort.





Contemporary approach

**Suitable for any furnishing
requirement imposed by
public spaces.**

Adatta ad ogni esigenza
d'arredo degli spazi





Meeting areas

**Robust to the extent
required for an intense use.**

Solida e perfetta per un uso
intensivo.

Pia

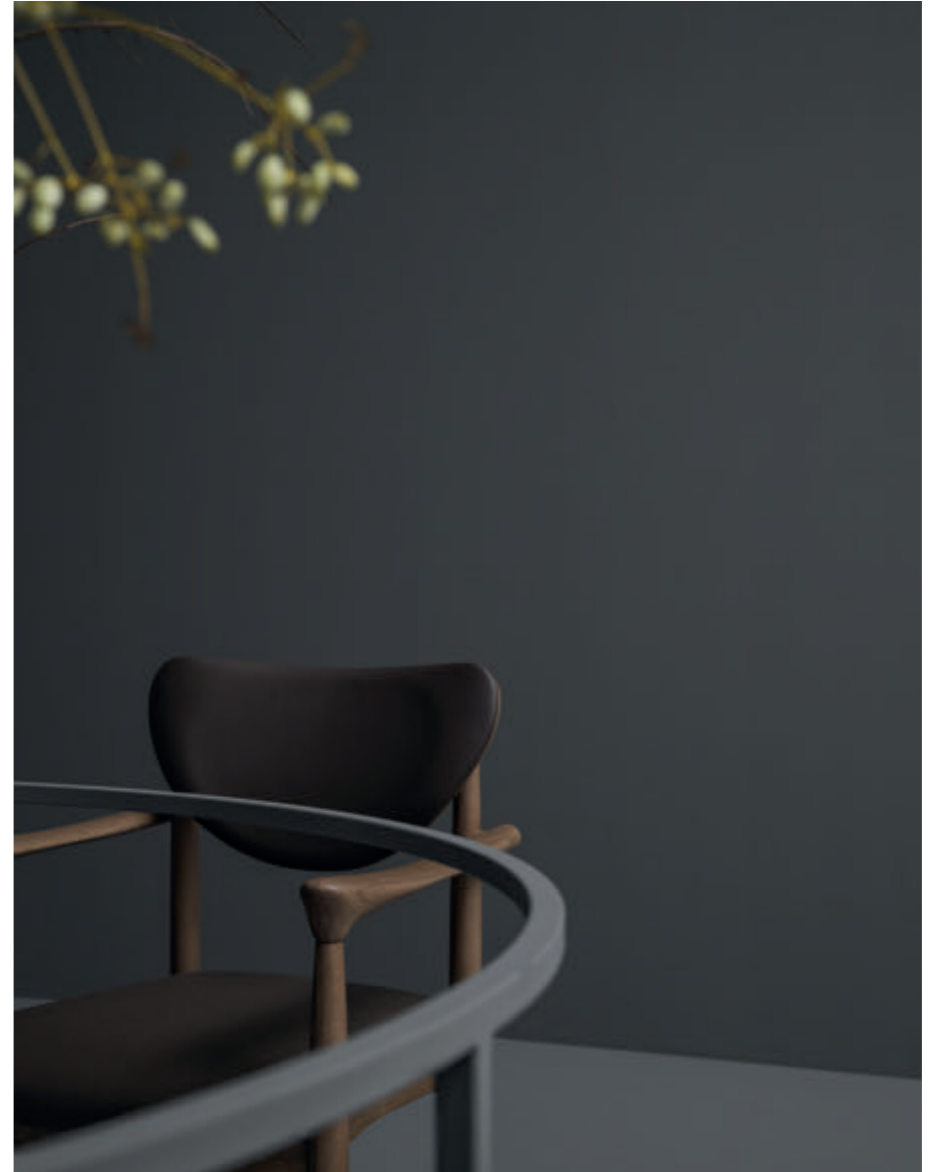



Pia
design Giulio Lazzotti

Elegant and contemporary settings. To feel comfortable, in an interior conveying a sense of sophistication.

Contract contemporaneo ed elegante. Sentirsi a casa, grazie ad un interior sofisticato.



Seductive accents

Soft, round edges mark a delicate and lightweight armrest.

Morbidi angoli arrotondati per il bracciolo dal segno particolare.





Focal point

**Meticulously execution
and skilful use of
natural materials.**

Esecuzione magistrale e
uso sapiente di materiali
naturali.





Praise to the details

The result of constant attention to technological innovation.

Frutto di un'attenzione costante all'innovazione tecnologica.





Matching many interior styles

**Ideal for both corporate and
hospitality environments.**

Perfetta per gli ambienti
dell'ospitalità e dell'attesa.



www.piaval.it

Across the families

CAMEO

design Edi e Paolo Ciani

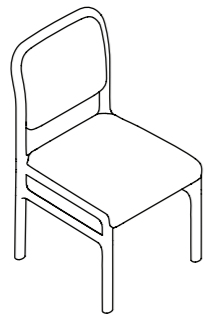
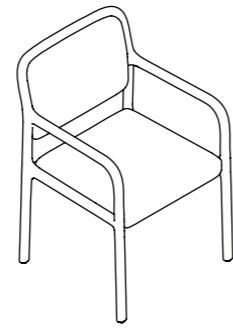
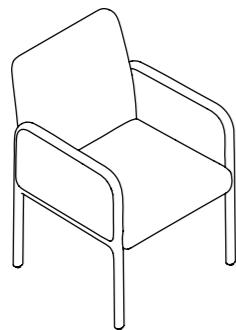
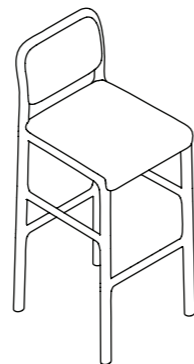
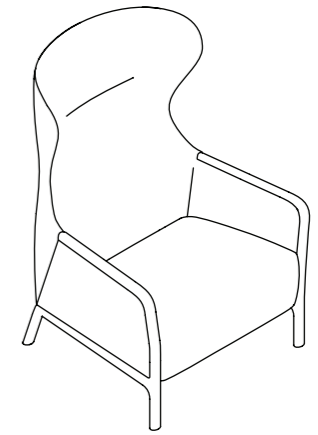
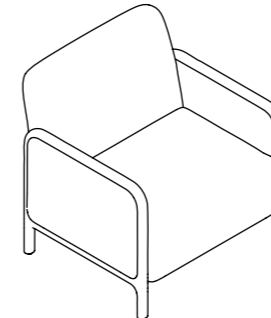
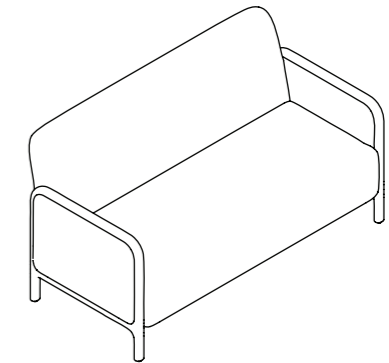
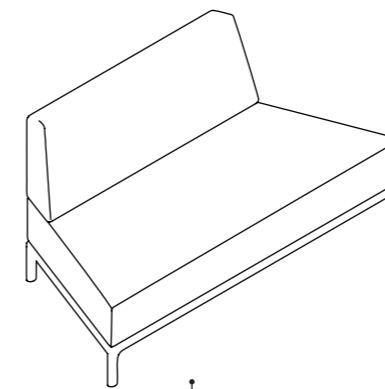
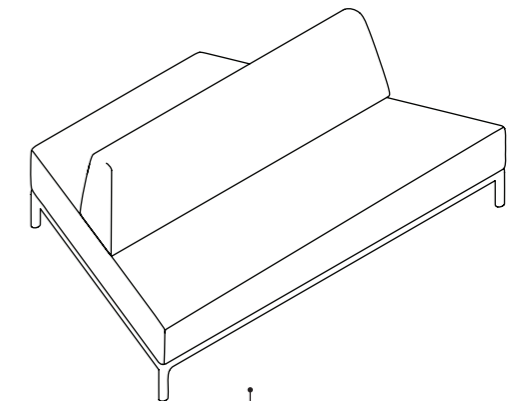
**87-11/1**Ash / Frassino
49 x 52 x 88 cmChair. Padded seat and back.
Sedia. Seduta e schienale imbottiti.**87-12/1**Ash / Frassino
56 x 55 x 88 cmChair with armrests. Padded seat and back.
Sedia con braccioli. Seduta e schienale imbottiti.**88-12/1F**Ash / Frassino
64 x 64 x 88 cmArmchair. Padded seat, back and side panels.
Poltroncina. Seduta, schienale e pannelli laterali imbottiti.**90**Ash / Frassino
44 x 48 x 108 cmHigh stool. Padded seat and back.
Sgabello alto. Seduta e schienale imbottiti.**100-62/3**Ash / Frassino
84 x 81 x 110 cmArmchair with high backrest, side headrest and shaped padding for maximum comfort. Armrests with ash wood profile.
Poltrona con schienale alto, poggiatesta laterale e imbottitura sagomata per il massimo comfort. Braccioli con profilo in legno di frassino.**89-62/1F**Ash / Frassino
85 x 76 x 82 cmArmchair with padded seat, back and side panels.
Poltrona con seduta, schienale e pannelli laterali imbottiti.**89-92/1F**Ash / Frassino
156 x 76 x 82 cmSofa with padded seat, back and side panels.
Divano con seduta, schienale e pannelli laterali imbottiti.**97**Ash / Frassino
238 x 74 x 81 cmSingle seater. Padded seat and back. Solid Ash / Frassino wood profile. The individual modules can be fitted together perfectly.
Modulo a seduta unica. Seduta e schienale imbottiti. Profilo in massello di frassino. I singoli moduli possono aderire perfettamente uno all'altro.**98**Ash / Frassino
202 x 132 x 81 cmSymmetrical module. Padded seat and back. Solid Ash / Frassino wood profile. The individual modules can be fitted together perfectly.
Modulo a seduta speculare. Seduta e schienale imbottiti. Profilo in massello di frassino. I singoli moduli possono aderire perfettamente uno all'altro.

LIV

design David Ericsson

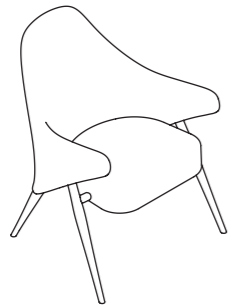
**60-12/1**Beech / Faggio
63 x 64 x 93 cm**60-12/2**Ash / Frassino
63 x 64 x 93 cm

Armchair with high, hugging backrest. Padded, shaped armrests.
Poltrona con schienale alto e avvolgente. Braccioli sagomati imbottiti.

Certified by CATAS

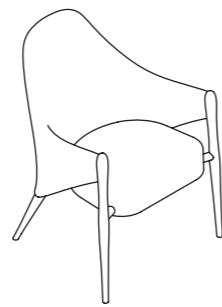
**60-13/1**Beech / Faggio
63 x 64 x 93 cm**300****60-13/2**Ash / Frassino
63 x 64 x 93 cm

Armchair with high, hugging backrest. Padded, shaped armrests and wooden hand grip. **Certified for loads up to 300 kg.**
Poltrona con schienale alto e avvolgente. Braccioli sagomati, imbottiti e impugnatura in legno. **Certificata fino a 300 kg di carico.**

Certified by CATAS

EARL

design Daniel Rous / Fabrica

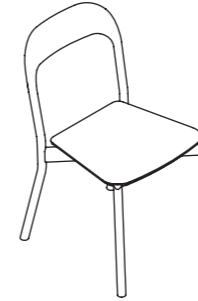
**94-11/4**Beech / Faggio
47 x 58 x 84 cm

Chair. Wooden seat and back. Shaped backrest for easy grip and handling.
Sedia. Schienale e sedile in legno. Schienale sagomato per facile presa e movimentazione. Impilabile.

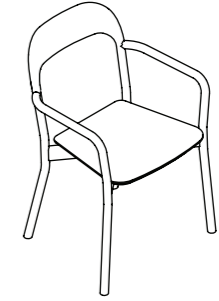
**94-12/4**Beech / Faggio
58 x 58 x 84 cm

Chair with armrests. Wooden seat and back. Shaped backrest for easy grip and handling.
Sedia con braccioli. Schienale e sedile in legno. Schienale sagomato per facile presa e movimentazione. Impilabile.

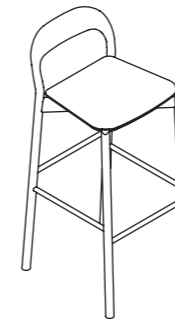
**101/4**Beech / Faggio
42 x 46 x 100 cm

High stool. Seat and back in beech wood. Legs with round section.
Sgabello alto. Seduta e schienale in legno di faggio. Gambe a sezione tonda.

ELSA
Rounded version

design David Ericsson

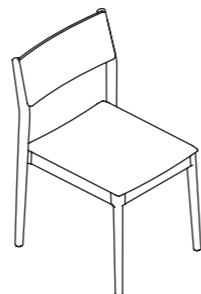
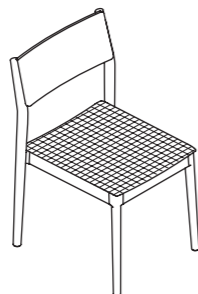
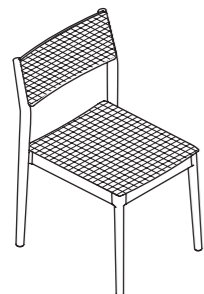

65-11/2	65-11/2F
Beech / Faggio 51 x 56 x 83 cm	Ash / Frassino 51 x 56 x 83 cm

65-11/3	65-11/3F
Beech / Faggio 51 x 56 x 83 cm	Ash / Frassino 51 x 56 x 83 cm

65-11/4	65-11/4F
Beech / Faggio 51 x 56 x 83 cm	Ash / Frassino 51 x 56 x 83 cm

Chair. Padded seat and back. Round legs. Stackable.
Sedia. Seduta e schienale imbottiti. Gambe a sezione tonda. Impilabile.

Chair. Padded seat, wooden backrest. Round legs. Stackable.
Sedia. Seduta imbottita, schienale in legno. Gambe a sezione tonda. Impilabile.

Chair. Wooden seat and backrest. Round legs. Stackable.
Sedia con braccioli. Seduta e schienale in legno. Gambe a sezione tonda. Impilabile.

Certified by CATAS

ELSA
Squared version

design David Ericsson

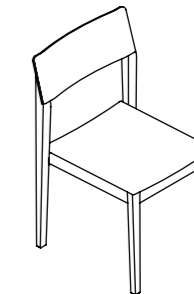
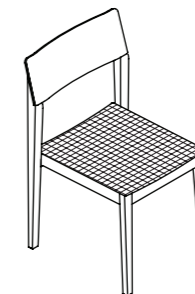
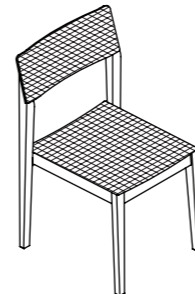

64-11/2	64-11/2R
Beech / Faggio 50 x 52 x 84 cm	Oak / Rovere 50 x 52 x 84 cm

64-11/3	64-11/3R
Beech / Faggio 50 x 52 x 84 cm	Oak / Rovere 50 x 52 x 84 cm

64-11/4	64-11/4R
Beech / Faggio 50 x 52 x 84 cm	Oak / Rovere 50 x 52 x 84 cm

Chair. Padded seat and back. Square legs. Stackable.
Sedia. Seduta e schienale imbottiti. Gambe a sezione quadrata. Impilabile.

Chair. Padded seat, wooden backrest. Square legs. Stackable.
Sedia. Seduta imbottita, schienale in legno. Gambe a sezione quadrata. Impilabile.

Chair with wooden seat and backrest. Square legs. Stackable.
Sedia con seduta e schienale in legno. Gambe a sezione quadrata. Impilabile.

Certified by CATAS

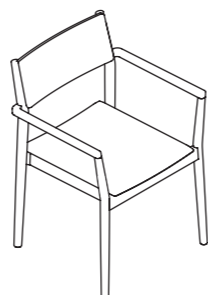
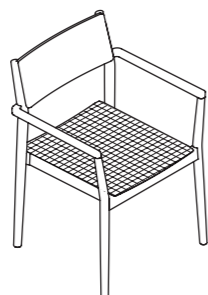
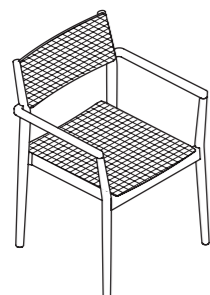

65-14/2	65-14/2F
Beech / Faggio 58 x 56 x 83 cm	Ash / Frassino 58 x 56 x 83 cm

65-14/3	65-14/3F
Beech / Faggio 58 x 56 x 83 cm	Ash / Frassino 58 x 56 x 83 cm

65-14/4	65-14/4F
Beech / Faggio 58 x 56 x 83 cm	Ash / Frassino 58 x 56 x 83 cm

Chair with armrests. Padded seat and back. Round legs. Stackable.
Sedia con braccioli. Seduta e schienale imbottiti. Gambe a sezione tonda. Impilabile.

Chair with armrests. Padded seat, wooden backrest. Round legs. Stackable.
Sedia con braccioli. Seduta imbottita, schienale in legno. Gambe a sezione tonda. Impilabile.

Chair with armrests. Wooden seat and backrest. Round legs. Stackable.
Sedia con braccioli. Seduta e schienale in legno. Gambe a sezione tonda. Impilabile.

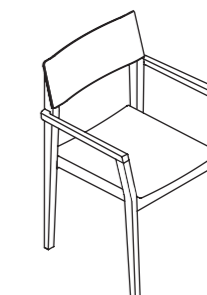
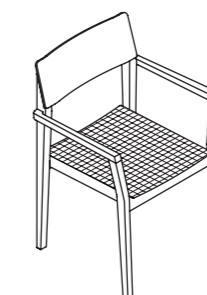
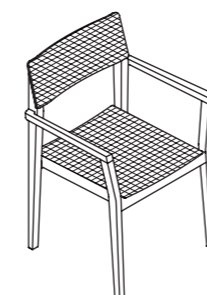

64-14/2	64-14/2R
Beech / Faggio 50 x 52 x 84 cm	Oak / Rovere 50 x 52 x 84 cm

64-14/3	64-14/3R
Beech / Faggio 50 x 52 x 84 cm	Oak / Rovere 50 x 52 x 84 cm

64-14/4	64-14/4R
Beech / Faggio 50 x 52 x 84 cm	Oak / Rovere 50 x 52 x 84 cm

Chair with armrests. Padded seat and back. Square legs. Stackable.
Sedia con braccioli. Seduta e schienale imbottiti. Gambe a sezione quadrata. Impilabile.

Chair with armrests. Padded seat and wooden backrest. Square legs. Stackable.
Sedia con braccioli. Seduta imbottita e schienale in legno. Gambe a sezione quadrata. Impilabile.

Chair with armrests. Wooden seat and backrest. Square legs. Stackable.
Sedia con braccioli. Seduta e schienale in legno. Gambe a sezione quadrata. Impilabile.

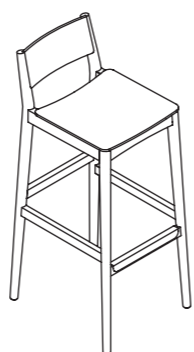
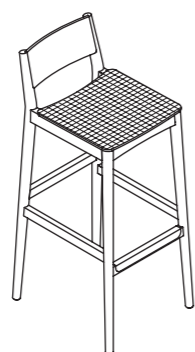
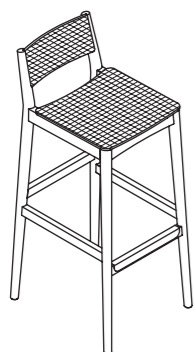

86-11/2	86-11/2F
Beech / Faggio 35 x 42 x 97 cm	Ash / Frassino 35 x 42 x 97 cm

86-11/3	86-11/3F
Beech / Faggio 35 x 42 x 97 cm	Ash / Frassino 35 x 42 x 97 cm

86-11/4	86-11/4F
Beech / Faggio 35 x 42 x 97 cm	Ash / Frassino 35 x 42 x 97 cm

High stool. Padded seat and back. Round legs.
Sgabello alto. Seduta e schienale imbottiti. Gambe a sezione tonda.

High stool. Padded seat, wooden backrest. Round legs.
Sgabello alto. Seduta imbottita, schienale in legno. Gambe a sezione tonda.

High stool with wooden seat and backrest. Round legs.
Sgabello alto con seduta e schienale in legno. Gambe a sezione tonda.

Piaval

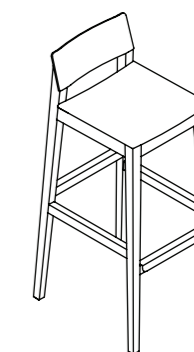
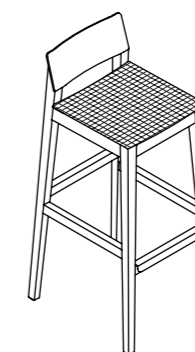
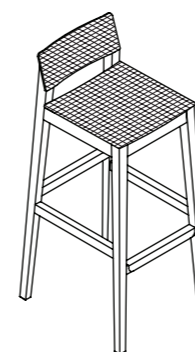

84-11/2	84-11/2R
Beech / Faggio 35 x 40 x 97 cm	Oak / Rovere 35 x 40 x 97 cm

84-11/3	84-11/3R
Beech / Faggio 35 x 40 x 97 cm	Oak / Rovere 35 x 40 x 97 cm

84-11/4	84-11/4R
Beech / Faggio 35 x 40 x 97 cm	Oak / Rovere 35 x 40 x 97 cm

High stool. Padded seat and back. Square legs.
Sgabello alto. Seduta e schienale imbottiti. Gambe a sezione quadrata.

High stool. Padded seat, wooden backrest. Square legs.
Sgabello alto. Seduta imbottita, schienale in legno. Gambe a sezione quadrata.

High stool with wooden seat and backrest. Square legs.
Sgabello alto con seduta e schienale in legno. Gambe a sezione quadrata.

Piaval

PIA

design Giulio Lazzotti

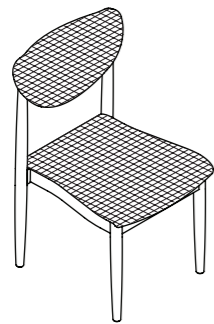
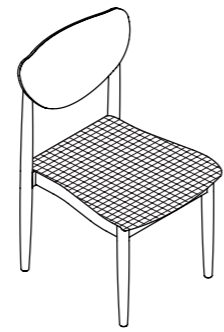
**48-11/2**Beech / Faggio
49 x 55 x 85 cmChair. Padded seat and back.
Sedia. Seduta e schienale imbottiti.**48-11/3**Beech / Faggio
49 x 55 x 85 cmChair. Padded seat.
Sedia. Seduta imbottita.

Certified by CATAS

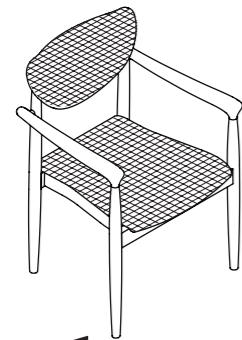
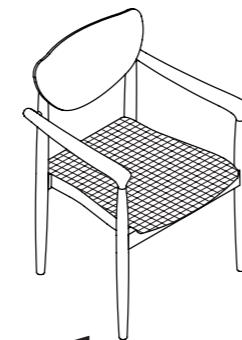
**48-13/2**Beech / Faggio
61 x 56 x 85 cmArmchair. Padded seat and back.
Poltroncina. Seduta e schienale imbottiti.**48-13/3**Beech / Faggio
61 x 56 x 85 cmArmchair. Padded seat.
Poltroncina. Seduta imbottita.the mark of
responsible forestry
Ask for FSC®
certified products



credits

Art direction
Garcia Cumini

Project coordination and
Graphic Design
Marco Brollo, MBad

Photo
Contratticompany

Styling
Daniela Moioli

Testi / Press Office
Adriana Cruciati / Calt

Printed by
Lithostampa
September 2017

Piaval srl
via del Collio 57
33048 San Giovanni al Natisone
T +39 0432 756046
F +39 0432 756815
info@piaval.it www.piaval.it

PIAVAL
